

## Alustage Instruction and Assembly Manual

- Application
- Transport
- Installation and Dismantling
- Suspending
- Equalizing potential
- Maintenance
- Damage
- Spare Parts
- Tests
- Wear criteria
- Structural analysis

READ THE MANUAL CAREFULLY AND FOLLOW THE INSTRUCTIONS. SAFE OPERATION OF THE TRUSS SYSTEM IS ONLY POSSIBLE BY COMPLYING WITH THESE RECOMMENDATIONS

### APPLICATION

Trusses and truss systems are intended exclusively for supporting primary static loads or for purely decorative purposes. They may be suspended, positioned, permanently mounted, or moved from one place to another

### TRANSPORT INSTRUCTIONS

Trusses must be properly secured against shifting during transport. Make sure the weight is evenly distributed. This is particularly important when heavy items have different specific weights. The load may be marked using appropriate labels. Always comply with road traffic regulations!

### INSTALLATION AND DISMANTLING PROCEDURES

All persons must use protective equipment and follow applicable accident prevention regulations. The truss installation must be carried out by qualified personnel following this instruction/user information. System stability must be ensured at all times during assembly, keeping the load-bearing capacity in mind. Before installation, visually inspect all components (truss elements, connectors, etc.).

If any visible defects are found — such as material deformation, shortening of the main chords or braces, cracks at or near welds, gaps forming in joints or fastenings, deformation of those connections — such parts must not be installed and must be clearly marked to prevent further improper use. Install trusses in the correct orientation. For installation or dismantling, only use appropriate tools — e.g., aluminum, plastic, or copper hammers, socket and/or spanner wrenches.

### PROPER ASSEMBLY OF SYSTEM COMPONENTS

For assembly details, please refer to the instructions provided on the reverse side of this brochure.

### CONNECTION INSTRUCTIONS (FORCE INDUCTION AND TRANSMISSION)

When applying forces, you must have knowledge of all types of loads and their effects on the trusses or their transmission to the base elements.

The type and nature of the forces acting on the trusses depend largely on the actual load-bearing capacity of the applied truss.

### WORKING LOADS

The introduction of loads must be carried out in accordance with the manufacturer's instructions. When applying working loads, it must be ensured that all loads act vertically and are evenly distributed on the main chords. Clearly one-sided loading can significantly reduce the load-bearing capacity of the truss base. Additional horizontal loads should be avoided, since the simultaneous application of vertical and horizontal forces may lead to exceeding the permissible stress of the truss. If such additional loading cannot be avoided, trusses designed to accommodate horizontal forces must be used. When both horizontal and vertical loads are applied simultaneously, separate static calculations must be performed.

### 2x LA 0,8

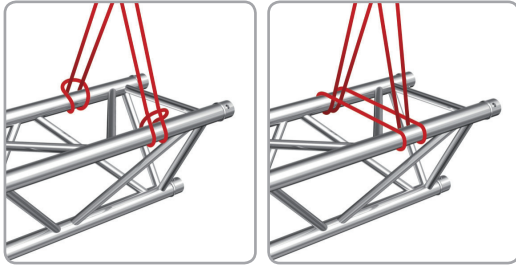

### LA x 2 - LA x 1,4

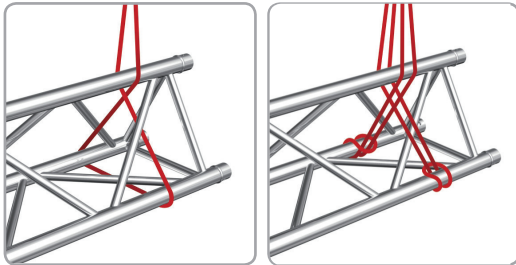

### INCORRECTLY!

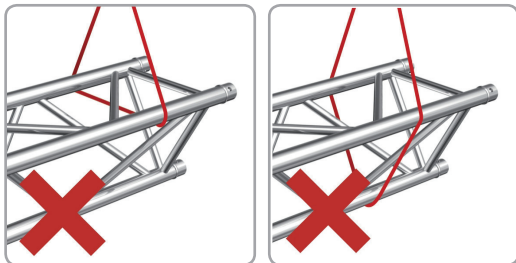

## SUSPENDING ELEMENTS ON STRUCTURES

Three basic types of suspension should be distinguished:

### a) Direct, simple hanging

This system uses rigid fastening elements such as clamps, couplers, profiles, or eye clamps

### b) Choked slings

In this method, round slings are used in pairs — one on each side of the truss — and then joined at a connector or hook.

However, note that when the upper or lower flange of the sling is choked, the sling's load capacity is reduced to about 80% of its nominal capacity, meaning that using two identical slings provides only about 1.6 times the rated capacity (depending on the external angle).

### c) Wrapped sling

In this method, the suspension elements are guided under the main chords and wrapped or stretched on both sides of the truss straight upwards, then looped around the main belts until stopped by the hook or connector.

This method increases the sling capacity by a factor of 1.4 to 2 of its nominal capacity (depending on the external angle).

External angles greater than 60° are not permitted.

**Note:** The suspension near the cross member should be mounted so that it can absorb compressive forces between the main chords.

*"LA" complies with the lifting device diagram developed by VMBG (BGI 622) according to DIN 1492 Parts 1 + 2.*

*"LA" = load-bearing capacity / depending on the loop reduction and angle = load factor.*

## POTENTIAL EQUALIZATION

Faulty truss systems may carry dangerous touch voltages and must be subjected to common potential equalization. This applies to all electrically conductive elements on which, or to which, devices are mounted or connected, or through which cables and wires pass that could be damaged by contact with metallic parts. The connection can be made using clips, clamps, screws, or special single-pole protected connectors. Common potential equalization must be connected to the protective conductor

For conductor sizing: 16 mm<sup>2</sup> Cu for conductor lengths up to 50 m; 25 mm<sup>2</sup> Cu for conductor lengths up to 100 m. In tower systems, potential equalization can be achieved through a port provided by the manufacturer at the tower base. Because tower systems with movable elements (e.g., sleeve blocks) use rollers or cylinders that insulate the moving truss assemblies, they must be additionally secured with separate potential equalization.

## OPERATION AND BEHAVIOR DURING USE

If trusses have been installed in such a way that people can move beneath them, it is extremely important to apply all relevant safety requirements and procedures to prevent potential hazards, as specified in document C1 "Stage and Production Facilities for Stage Performances by BGV. When trusses are used in areas where people gather, the national legal regulations must also be observed — for example, public assembly regulations specifying requirements for the erection of structures in new open-air locations or for so-called "temporary structures" (FIBauR)

## MAINTENANCE INSTRUCTIONS

Do not use any lubricating substances for maintaining truss connecting components.

Trusses should be cleaned only with water and/or a soft cotton cloth.

## PROCEDURE IN CASE OF DAMAGE

If any damage occurs during truss installation or dismantling, the truss must be immediately removed from service and clearly marked to prevent accidental further use.

Then contact your Alustage dealer to discuss the next steps.

## STRUCTURAL CALCULATIONS

All Alustage trusses are statically calculated as single-span systems. If the truss is used as a multi-span or outdoor system, an additional structural static analysis must be performed for the specific configuration. The operator may commission such an analysis from any structural engineering office. The system-specific truss statics provided by the manufacturer serve as the basis for such calculations and are available upon request.

# INSTALLATION INSTRUCTIONS FOR ALUSTAGE DUO, TRI, QUA SERIES

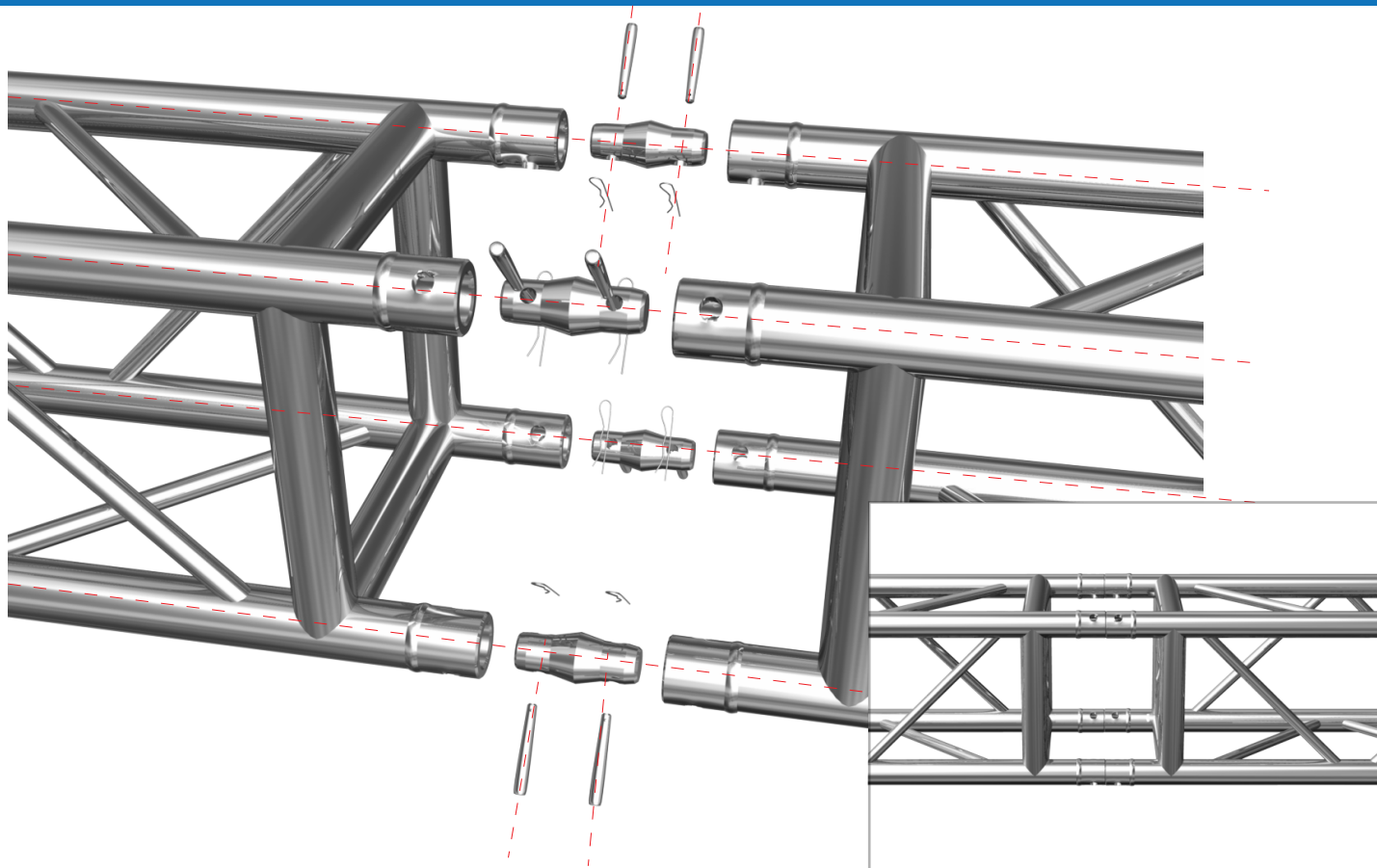

## Installation

Unpack the trusses and lay them out on a flat surface.

The connectors are located on the side opposite to the direction of load pressure.

Mount the conical connectors on one side of the truss.

Insert the mounting pins and align the conical connectors. Both parts are mechanically press-fitted.

Drive in the locking pins and secure them with the R-shaped safety clip.

**Note:** All safety clips must be firmly driven into place after joining components.

For frequent assembly and disassembly, it is recommended to use M8 threaded conical bolts.

Single-sided conical assembly sets accelerate mounting and dismantling operations and prevent the loss of conical or other connectors. When erecting circular, elliptical, or other irregular structures, the driving of conical connectors should only take place after the entire structure has been assembled.

Load specifications for Litetruss Systems components can be found in the latest main product catalog.

For any questions, please contact your local representative or Alustage directly — we will gladly provide assistance.

## SPARE PARTS INFORMATION

Only original Alustage spare parts may be used. They can be obtained from your authorized Alustage dealer.

## PERIODIC INSPECTION INFORMATION

Truss systems must be inspected according to their type and frequency of use to detect defects and faults.

A qualified person must perform a periodic inspection at least once per year.

The inspections shall focus particularly on:

- |                                 |  |
|---------------------------------|--|
| a) Deformations                 | (bending, twisting, etc.)                            |
| b) Defects                      | (cracks, holes, etc.)                                |
| c) Missing parts                | (connecting clamps, diagonal braces, couplers, etc.) |
| d) Fulfillment of wear criteria |  |

If visual inspection raises doubt about the truss's condition, another inspection method must be used (e.g., color penetration testing, ultrasonic testing).

The person performing the inspection is required to record the results in an inspection log or audit document.

Information about relevant test certificates is available in BGV C1 §35

## WEAR CRITERIA INFORMATION

Truss wear is considered to have occurred when any of the following conditions affecting the safety of use are observed:

## STRUCTURAL PROFILES

- a) Reduction in cross-sectional area due to wear (Main chords and connecting/diagonal braces)
- b) Reduction in weld thickness due to wear
- c) Plastic deformation of profiles
- d) Holes or perforations in profiles
- e) Missing profiles or diagonal reinforcements/braces
- f) Displacement of load-bearing profiles (misalignment with other elements)
- g) Cracked welds
- h) Improper repairs
- i) Corrosion of structural components

## CONNECTORS AND COUPLING ELEMENTS

- a) Wear or reduction in cross-section of connectors due to abrasion
- b) Reduction in weld thickness caused by wear
- c) Plastic deformation of connectors
- d) Enlargement of holes
- e) Plastic deformation of connecting elements
- f) Corrosion marks on connectors and fastening elements
- g) Corrosion traces between load-bearing profiles, connectors, and joints
- h) Cracked welds
- i) Improper repairs

## ACCESSORIES

### Single clamp

Product code: KL231



### Double clamp

Product code: KL204GT



### T-25 Adapter 240/290

Product code: T 25

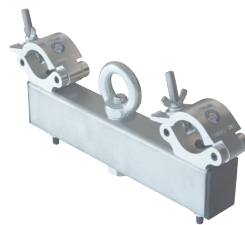

### BCorner 240/290

Product code: T 19

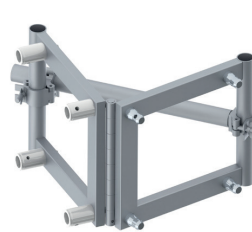

### QUA BOX

Product code: QUA290-BOX



### Base for Tri 290

Product code: PDS07.00

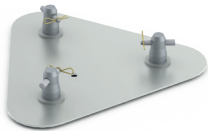

### Truss Cart

### Base for Qua 290

Product code: PDS08.00

