

Product Datasheet

VMC 500-15-XXb

500kg C1 Electric Chain Hoist with Direct Control

500 kg

C1

15 m/min

Vario

UC 1-6

EN17206



Moveket GmbH
Rudolf-Diesel-Straße 21
71154 Nufringen, Germany



Web: www.moveket.de
E-Mail: support@moveket.de
Phone: +49 7032 371170

Overview

Table of Contents

1. General Description	3
2. Technical Data	4
2.1 Specifications	4
2.2 Equipment	4
2.3 Electrical Data	4
2.4 Mechanical Data	4
2.5 Operating Conditions	4
3. Dimension Sheet	5
4. Connection Assignments	6

Figure Directory

Fig. 1	Overview drawing	4
Fig. 2	Dimension Sheet	5
Fig. 3	Connection Assignments	6
Fig. 4	Brake Circuitry	6

Revision Management

1.0	19.11.2024	DS	N. Braun	Initial Creation
-----	------------	----	----------	------------------



General Description

Model Designation

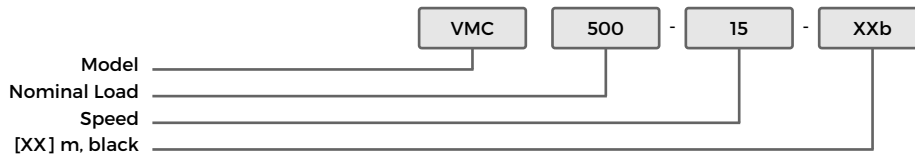

Moveket is a leading manufacturer of electric chain hoists, control systems, and safety technology. Our products stand for the highest level of safety, compact design, and "Made in Germany" quality. With over 35 years of experience in stage technology, we offer innovative solutions suitable for both permanent installations and touring operations.

Functionality

Our electric chain hoists are based on a modular design principle and can be flexibly configured. For example, load cells, incremental encoders, or gear limit switches can be easily retrofitted. Moveket's product range covers all applications for Use Cases 1 to 6 in accordance with EN 17206 and offers tailored solutions in various configurations, including D8 and D8+ setups. Moveket places the highest emphasis on precision and reliability to meet the demands of modern stage operations.

Application

Moveket's electric chain hoists are suitable for both stationary installations and mobile use in touring productions. They are ideal for stage and event technology, providing a safe and efficient solution for demanding projects worldwide.

Additional Features

Our products combine safety, durability, and ease of use. The compact dimensions and versatile configuration options ensure optimal adaptation to any requirement. Thanks to their modular design, subsequent adjustments can be easily implemented.

Box-Building Principle

The Moveket Box-Building Principle allows us to customize and flexibly expand our products. Various components such as load measurement systems, additional safety features, or specialized control modules can be integrated at any time to meet the demands of an ever-changing market. Do you have any questions or need further information? Feel free to contact your Moveket dealer, distributor, or reach out to us directly as the manufacturer.

2006/42/EG Machinery	2014/35/EU Low Voltage	2014/30/EU EMI	2011/65/EU RoHS	12100 DIN EN ISO	62061 DIN EN IEC	61000 DIN EN IEC
-------------------------	---------------------------	-------------------	--------------------	---------------------	---------------------	---------------------



VMC 500-15-XXb
Datasheet [EN]
Customer Release
VO.2; 29.10.24

© 2024 Moveket GmbH. All rights reserved. This document is subject to copyright and is the property of Moveket GmbH. Any reproduction, distribution, or other use, even partially, is not permitted without the express consent of Moveket GmbH. Images and photos show example configurations. Errors and technical changes reserved.

Technical Data

Technical Specifications

Model	VMC 500-15
Type	SK070/19
Motor	KPRE 80G2
Maximum Load	500 kg
Safety	8 dynamic
Load Strands	1
Brake Type	DC double brake
Lifting Speed 50Hz	15 m/min
Lifting Height	to 40 m
Chain Type	7x22
Gear Group	1Bm/M3
Usage Duration	400 h
Noise Level	74 dB(A)

Electrical Data

Operating Voltage	380 V AC - 420 V AC
Control Type	Direct Control
Control voltage	380 V AC - 420 V AC
Frequency	50 Hz
Power Factor cos(phi)	0.85
Electrical Nominal Power	1.44 kW
Current Consumption	4.26 A

Mechanical Data

Mechanical Nomin. Power	1.23 kW
Dimensions [L,W,H]	559 x 311 x 281
Weight Without Chain	37 kg
Chain Weight	1.10 kg/m
Nominal Speed	2850 1/min

Operating Conditions

Duty Cycle at +40°C	40 %
Max. Switching Cycles /h	240
Temperature Range	-20°C to +40°C
Protection Type (IP)	55

Overview drawing

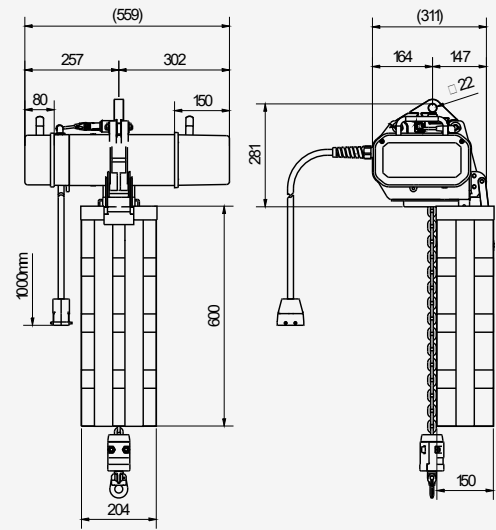

Model Variant: Std Installation Position

Suspension	Load Measuring Eyelet
Load Handling	Swivel Eye
Chain Introduction	Chain Introduction (Easyplate)
Chain Storage	Textile

Equipment: Direct Control

Gear Limit Switch	Yes
Dynamic Load Measuring Device	Yes
Incremental Encoder	Yes
Absolute Encoder	Yes



Technical Dimensions

